

Name:

Date:

SPH3U Unit E Test

Knowledge /15	Thinking /10	Application /15	Communication /10

Knowledge: Multiple Choice + Matching

1	2	3	4	5
6	7	8	9	10

*****Write your selected answers in this table.**

- 1) In order for a circuit to be complete, it must contain :
 - a) A load and a power source
 - b) A load, a power source and conducting wires
 - c) A load, a switch and conducting wires
 - d) A load, a power source

- 2) The electric potential difference (voltage) in a parallel component of a circuit will be _____ across both of the parallel loads.
 - a) Different
 - b) Equivalent
 - c) non-existent
 - d) very high

- 3) Which of the following components DO obey Ohm's Law?
 - a) LED's
 - b) Transistors
 - c) fluorescent lights
 - d) Resistors

- 4) Magnetic field lines run _____ to _____ OUTSIDE a bar magnet.
- a) North to South
 - b) South to North
 - c) North to North
 - d) South to South
- 5) Which of the following ways of generating power uses a NON-RENEWABLE resource?
- a) Wind powered turbines
 - b) Coal powered turbines
 - c) Hydroelectric powered turbines
 - d) Geothermal powered turbines
- 6) In a SERIES circuit, there is _____ for the current to flow.
- a) More than one path
 - b) Only one path
 - c) No path
 - d) Two paths
- 7) A circuit that has a power source and conducting wires ONLY is called:
- a) A power circuit
 - b) A long circuit
 - c) A short circuit
 - d) A broken circuit
- 8) The law of magnetism states that:
- a) Like magnetic poles repel and unlike poles attract each other.
 - b) Unlike magnetic poles repel, and like poles attract each other.
 - c) Magnets neither repel nor attract one another.
 - d) Like magnetic poles attract, and unlike poles repel each other.

- 9) Domains are...
- a) Small regions with intense magnetic fields within a material
 - b) A website address
 - c) Small areas in space
 - d) An area of an unmagnetized material

10) Oersted's principle states that:

- a) When a current moves through a conductor, it DOES NOT produce a magnetic field.
- b) When a magnetic field moves through a conductor, it induces a current.
- c) When a current moves through a conductor, it creates a magnetic field.

Matching [5K]

11) Match each of the following terms with the correct definition.

	Magnetic Field	A) This is a container consisting of one or more cells, in which chemical energy is converted and used as a source of power.
	Ohm's Law	B) This is a device that converts mechanical energy into electric potential energy.
	Generator	C) This is a device that transfers electrical energy from one circuit to another.
	Transformer	D) $V = IR$
	Battery	E) A region around a magnetic material or a moving electric charge which the force of magnetism acts.

Application [15 marks]

12) Draw a circuit which contains two loads in parallel, a voltmeter measuring electric potential difference across one of the loads, a switch, a battery and an ammeter measuring the current going into the junction. [5A]

13) A solenoid is moved away from a bar magnet as shown in the figure below. Determine the direction of the induced current through the ammeter. Explain how you determined your answer. [4A]



14) Recall the factors that affect the electromotive force and the induced current. Explain how you would manipulate the factors in order to maximize emf and induced current. [3A]

15) A thin conducting wire 0.80 m long is perpendicular to a magnetic field of magnitude 0.15 T. What is the current in the wire to create a force of 0.600 N [up]? [3A]

Thinking [10 marks]

16) For the following circuit, **determine the electric potential difference across each resistor, AND determine the current through each resistor.** Four marks will be given for the final correct answers, and four marks will be given for the work shown. When you have calculated your final answers, write them in the provided table below. [8T]

A series-parallel combination circuit

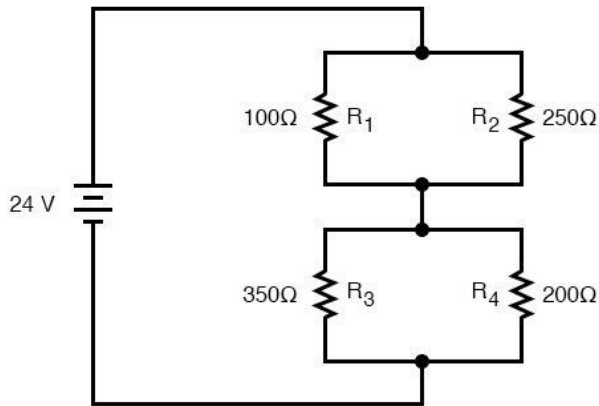

V_{R1}	V_{R2}	V_{R3}	V_{R4}
I_{R1}	I_{R1}	I_{R3}	I_{R4}

17) A student applies a current to a wire that is inside an external magnetic field, but no force acts on the wire. Provide a possible explanation for this. [2T]

Communication [10 marks]

18) Explain the conditions which are necessary for a wire to experience a magnetic force. [3C]

19) List TWO ADVANTAGES and TWO DISADVANTAGES of nuclear power plants. [4C]

18) Explain what a transformer is and why it is used. [3 C]